

INSTALLATION INSTRUCTION FOR TURBO 400 "CLEAN NEUTRAL" BRAKE KIT (#22024)

Thank you for purchasing a Coan Racing performance product. For over 25 years Coan Engineering has been the leader in hi-performance race transmissions and converters. Our ongoing research and development assures that you have purchased the best products available.

*** COMMITMENT * PERFORMANCE * RELIABILITY * A WINNING COMBINATION ***

The scope of these instructions will be aimed at the installation of this kit and it is assumed that the transmission will be rebuilt properly to work with this valve body. If necessary refer to a transmission manual for detailed instructions on disassembly and reassembly of the Turbo Hydramatic 400 transmission.

Note: Valve body is full manual with reversed shift pattern. (P-R/N-1-2-3-N) As a safety feature, the Trans brake is only functional in first gear. Clean Neutral Brake has a reverse lockout feature, to activate reverse depress brake switch with shifter in R/N position.

Kit Components:

1. Valve body/machined
2. Separator plate
3. Manual valve
4. Rear accumulator spring
5. Solenoid and o-ring
6. (16) Direct Clutch Springs
7. Brake valve
8. Brake valve spring

Requirements:

1. COA-22814 Aluminum Direct Drum (7075 Billet) Assy. W/34 Element Sprag or COA-22815 Aluminum Direct Drum (7075 Billet) Assy. W/Super Sprag
2. P08-408 or P08-458 Precision Performance Products shifter made specific for this shift pattern

Assembly of Direct Drum

1. Install piston and 16 new springs furnished. Replace retainer and snap ring. Assemble clutches and steels. A .050 - .060 clutch pack clearance is recommended. Install drum, discard front band, and reassemble transmission.
2. Remove valve body, separator plate, and gaskets. Discard all check balls. Remove rear servo assembly. *figure 1* Remove and discard oil-sealing rings from accumulator piston and discard stock accumulator spring *figure 2*. Install new accumulator spring furnished in kit and replace servo assembly and cover. *figure 3* For installations in late model cases that are equipped with a factory installed restriction in the Reverse Servo Piston apply hole, remove and discard the restrictor. The restrictor resembles a freeze plug installed in the apply hole. *figure 4*

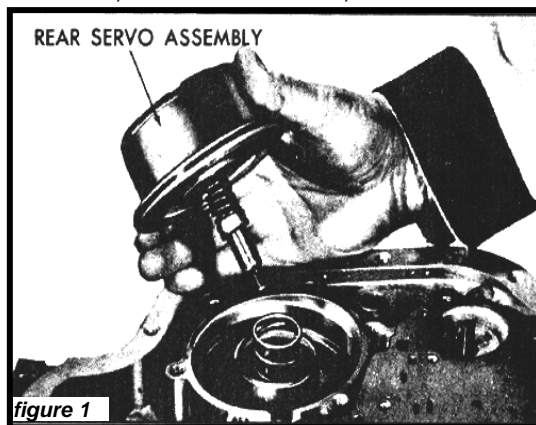

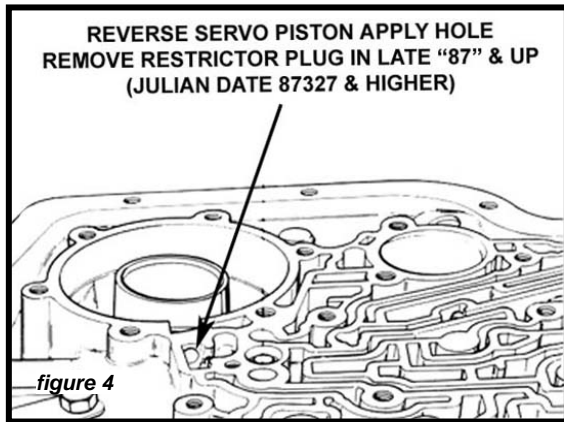
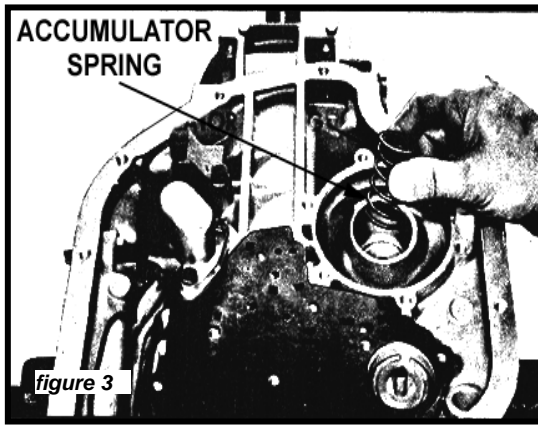
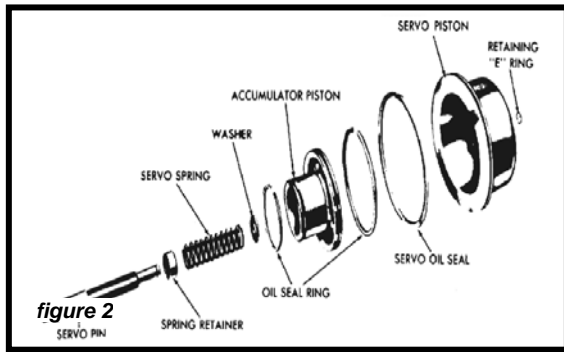

3. Install new valve body. Governor tubes can be omitted, unless using old style long filter, in which case one tube can be replaced as a filter support.
4. Use new separator plate with no gaskets and manual control valve furnished.
5. Remove and discard modulator and modulator valve. Place spring furnished over new valve and install in case making sure the new valve moves freely and the spring is functional.

Next install the solenoid with "O" ring in the modulator position and tighten in place with the stock modulator clip.

***NOTE:** Cooler fittings should never be plugged. If a cooler is not used, connect the lines together with a loop.

After assembly of transmission is completed, necessary wiring for the solenoid can be done. Position the momentary switch on the shifter or wherever it is comfortable. Run a wire from lead of switch to a twelve volt source, the other lead is connected to the red (+) wire on the solenoid. The black (-) wire on the solenoid should be connected to a good clean chassis ground. Be sure to use good wiring connections.

If you have any questions regarding the proper installation and/or operation of a Coan Racing product, please call (765) 456-3957. You may also fax us at (765) 456-3960, or e-mail at coan@coanracing.com.

Warranty

Coan Engineering offers a limited warranty covering all new products for ninety days and all repair service for thirty days from the original date of purchase to be free from flaws in material and craftsmanship. The warranty is non-transferable. Under no circumstances will Coan Engineering extend its warranty to products, new or repaired, which have been abused, misused, or incorrectly installed. Disassembly of any product by means other than a Coan Engineering technician will void any potential warranty. All warranty claims must be accompanied by the original invoice and are subject to the approval of Coan Engineering.

The above stated warranty **does not include** any shipping charges or labor charges for installation or removal of any Coan Racing product.

Liability

In no manner, neither written nor implied, does Coan Engineering accept liability for consequential or incidental damages to person or property resulting from the use or misuse of its products. Product failure occurring within the stipulations of the warranty policy will be dealt with explicitly under those particular guidelines.

